

# SAP FORUM 2010

CLAREZA PARA UM NOVO BRASIL

## Coca Cola Bottling utilizes DB2 to lower TCO



Andrew Juarez, Coca Cola Bottling Company Consolidated  
March 11, 2010

# SAP FORUM 2010

CLAREZA PARA UM NOVO BRASIL

## Agenda



1. About CCBCC
2. Why DB2?
3. Migration
4. Benefits
5. Post migration
6. Satisfaction?

Coca Cola Bottling Company Consolidated

**Industry:** Consumer products  
**Revenue:** US\$1.4 billion  
**Employees:** 6,000  
**Headquarters:** Charlotte, NC

**Web Site:** [www.cokeconsolidated.com](http://www.cokeconsolidated.com)

Coca-Cola Bottling Co. Consolidated, the second-largest Coca-Cola bottler in the United States, is a leader in the manufacture and distribution of soft drinks, primarily Coca-Cola products. It has operations in 11 states and a consumer base of 19 million people.

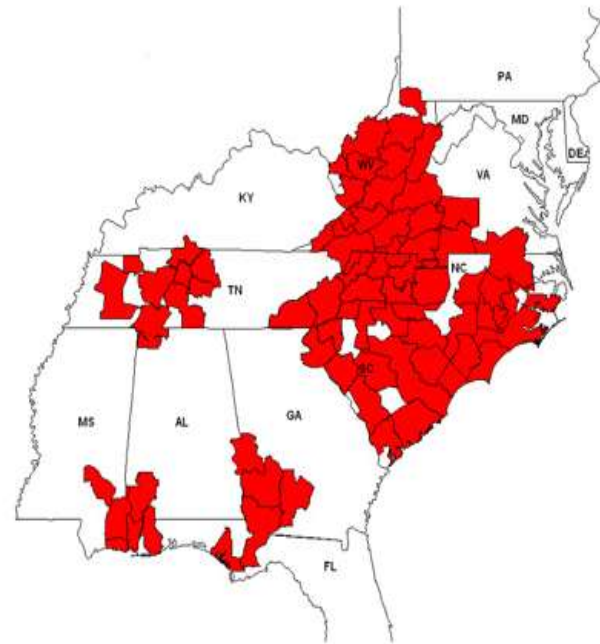

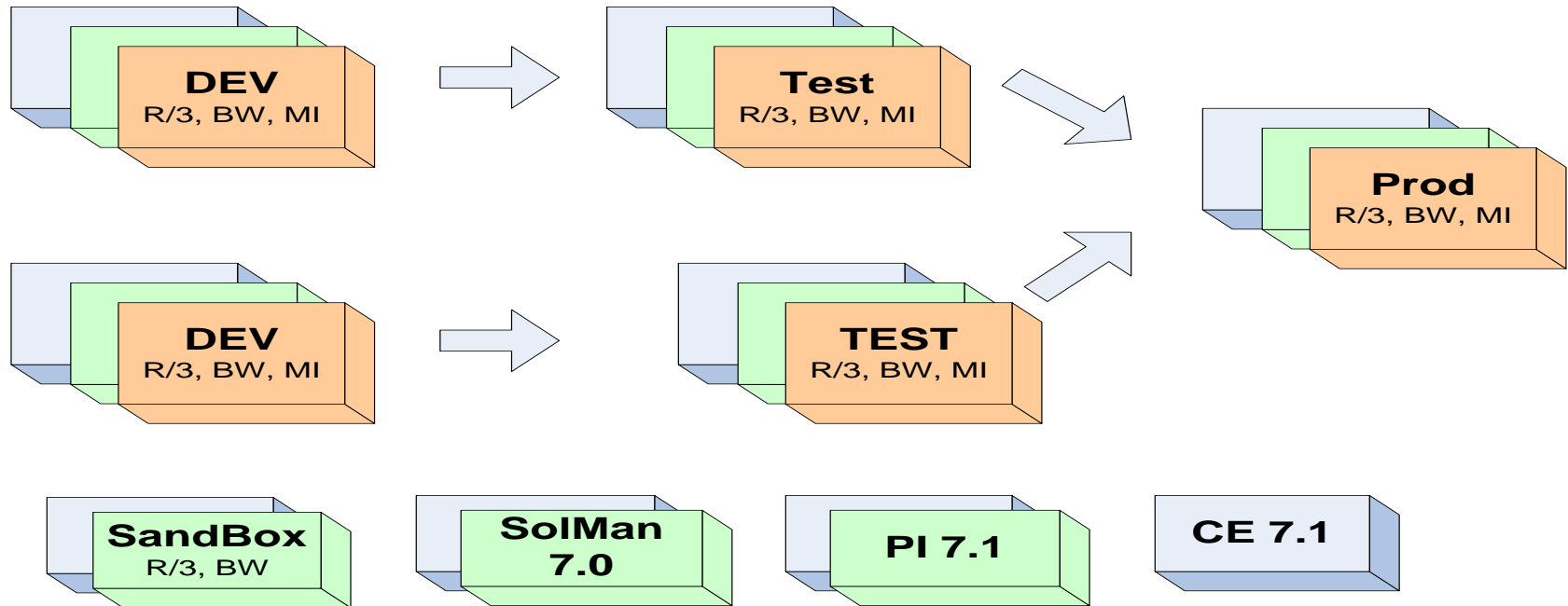

**R/3 4.7 Enterprise (7)**  
**Solution Manager NW7.0 (2)**  
**PI 7.1 (2) – installed with DB2**

**MI/MAM NW2004 (5)**  
**BW 3.5 (6)**  
**CE 7.1 (1) – installed with DB2**



## ■ Hardware @ migration

- CI/DB's run on IBM P560's with AIX5.3
- Application Servers run on Dell 2950 with SUSE 10 Linux
- BW runs exclusively on Dell and SUSE
- EMC storage – All SAP systems - 5 terabytes

# SAP FORUM 2010

CLAREZA PARA UM NOVO BRASIL

## Agenda



1. About CCBCC
2. Why DB2?
3. Migration
4. Benefits
5. Post migration
6. Satisfaction?

Coca Cola Bottling Company Consolidated

- Technical Upgrades to R/3 & BW systems required Oracle Upgrades. Also considered a possible R/3 Unicode conversion as well.
- Needed additional Oracle licenses for new SAP systems.
- Early 2008 we learned about the SAP/DB2 offering from KO
  - Included the cost for DB2 as part of the SAP user license
  - This offering allowed us to avoid purchasing new Oracle licenses
  - Allowed us to reduce our overall Oracle licenses and maintenance costs

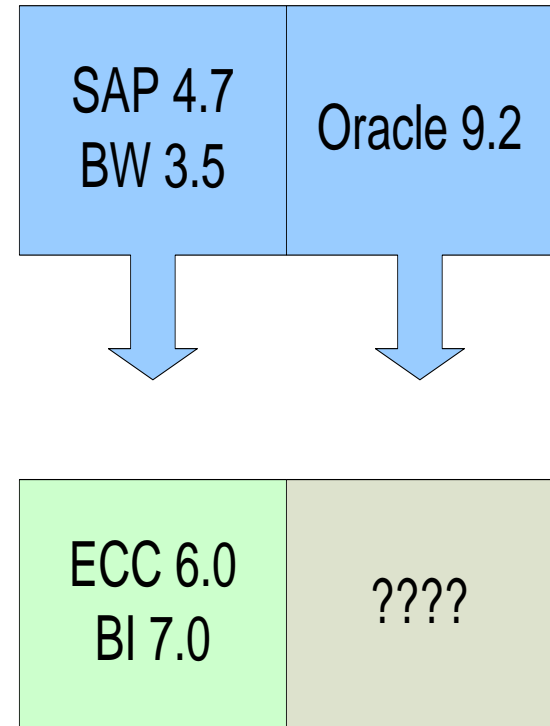



- **Hurdles with moving to DB2**
  - Basis Team were Oracle experts.
  - Team Buy-in was key.
  - Getting a large enough outage window
  - Had no idea if DB2 would be more work in the long run

# SAP FORUM 2010

CLAREZA PARA UM NOVO BRASIL

## Agenda



1. About CCBCC
2. Why DB2?
3. Migration
4. Benefits
5. Post migration
6. Satisfaction?

Coca Cola Bottling Company Consolidated

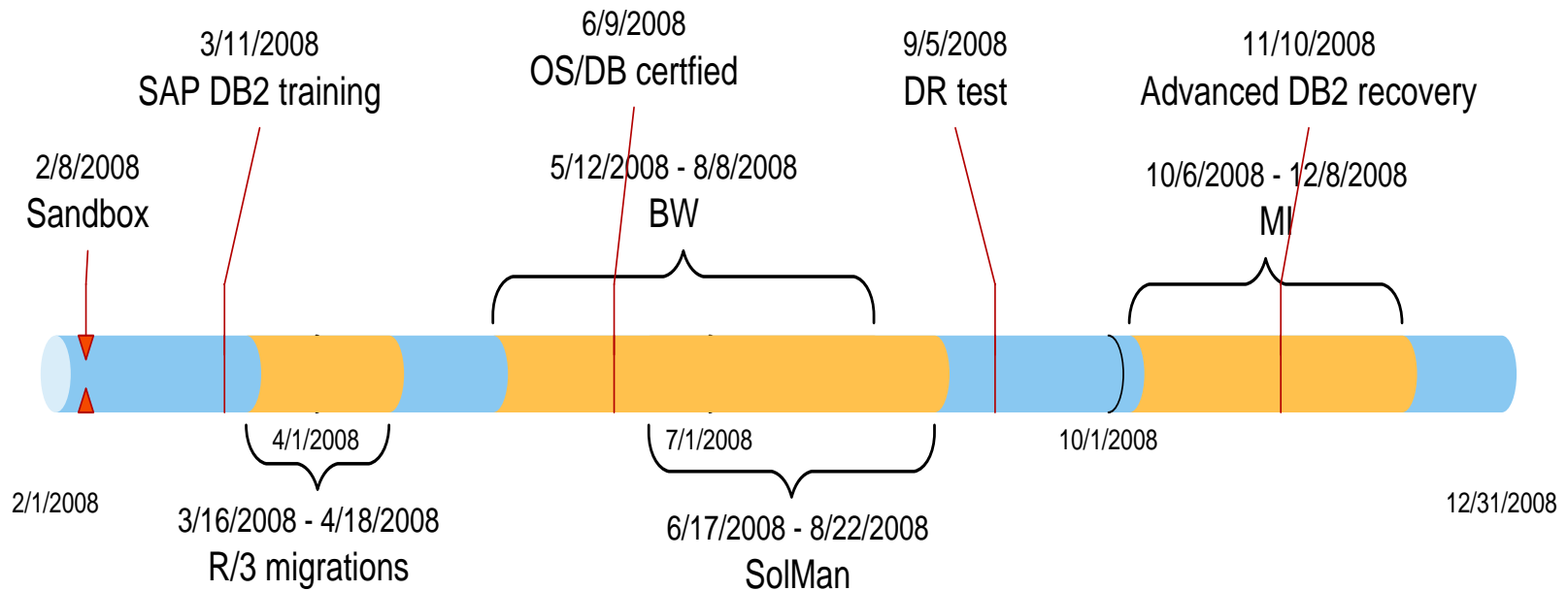

- Project started in February 2008
- R/3 Landscape migrated by April (7)
- BW Landscape migrated by Aug (6)
- SolMan Landscape migrated by Aug (2)
- MI Landscape migrated by December (5)



## ■ Migration partner

- Talked to both SAP and IBM about our project
- Selected IBM as our migration partner for R/3, BW and MI landscapes.
- Only used IBM for R/3 landscape
- Sent Lead Basis Technician to SAP migration class and had him certified for migrations.
- CCBCC Basis team performed all other migrations.

## ■ **Dev, Test and Sandbox migrations**

- Recreated host on either a Virtual or Physical machine
- If needed, performed Unicode pre-work 2 days prior to migration
- Scheduled 3 day outage per system
- Export overnight
- Import next day
- Finish installing SAP system
- If needed, performed Post unicode work
- If needed, export / import Java stack
- Set database parameters
- Backup system
- Run stats
- Run SGEN
- Re-install any application servers

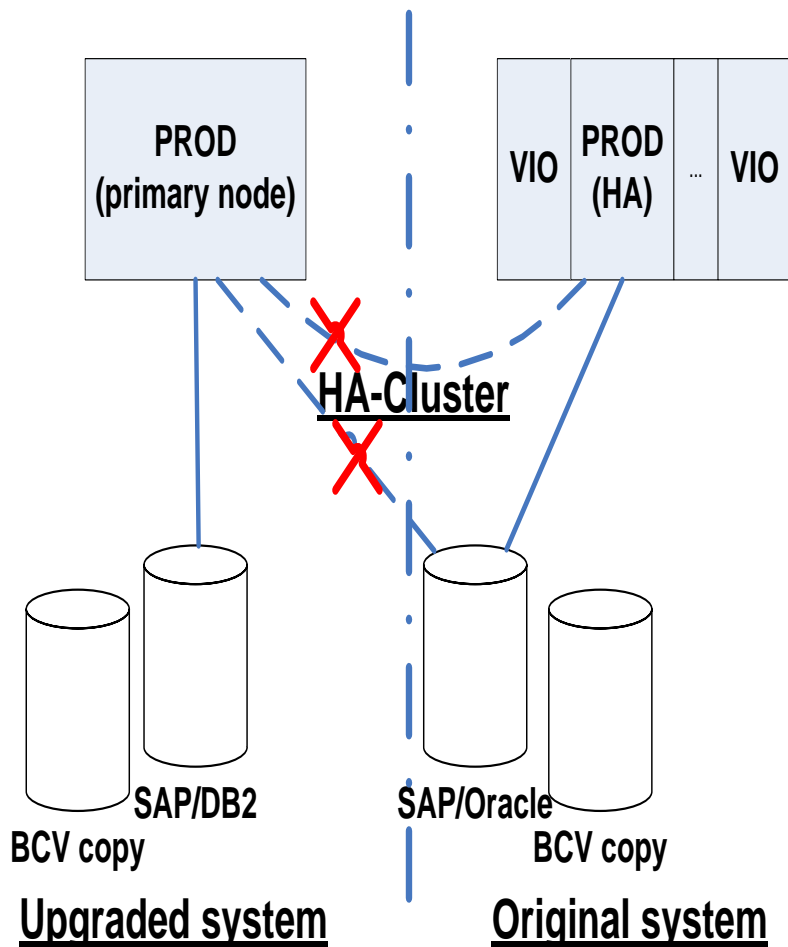

## ■ Production migration process

- Week before, failed HA cluster to backup node and ran as a single node cluster
- Prepped the main node for DB2.
- Unicode pre-work started 3 days prior to migration
- Scheduled 18 hour outage
- Ran Export and Import at the same time.
- Finish installing SAP system
- Post UNICODE work
- Set database parameters
- Backup system
- Run stats
- Run SGEN twice (AIX, Linux)
- Re-install application servers

## ■ Results of the migration

- Actual migration was completed in 23 hrs
- Had issues with DBTABLOG table
- EDI40 cluster table took longer than expected
- A few minor performance issues that were fixed with indexes.
- Issues generating explain plans
- No real unicode issues encountered
- Issues with SAP license key
- DB2 learning curve was easier than expected.

# SAP FORUM 2010

CLAREZA PARA UM NOVO BRASIL

## Agenda



1. About CCBCC
2. Why DB2?
3. Migration
4. Benefits
5. Post migration
6. Satisfaction?

Coca Cola Bottling Company Consolidated

## ■ Tangible and in-tangible benefits

- An ROI of 8 months and a \$500k savings first year.
- DB2 is better integrated into SAP
- DB2 requires less attention from the Basis DBA than Oracle
- Experienced some performance gains on batch jobs
- DB2 fixes are available for use immediately
- Saved over 2 terabytes in storage
  - R/3 Due to reorg and DB2 deep compression
  - Production went from 950 GB to 575 GB even with the Unicode conversion

## SAPPRD Database Growth

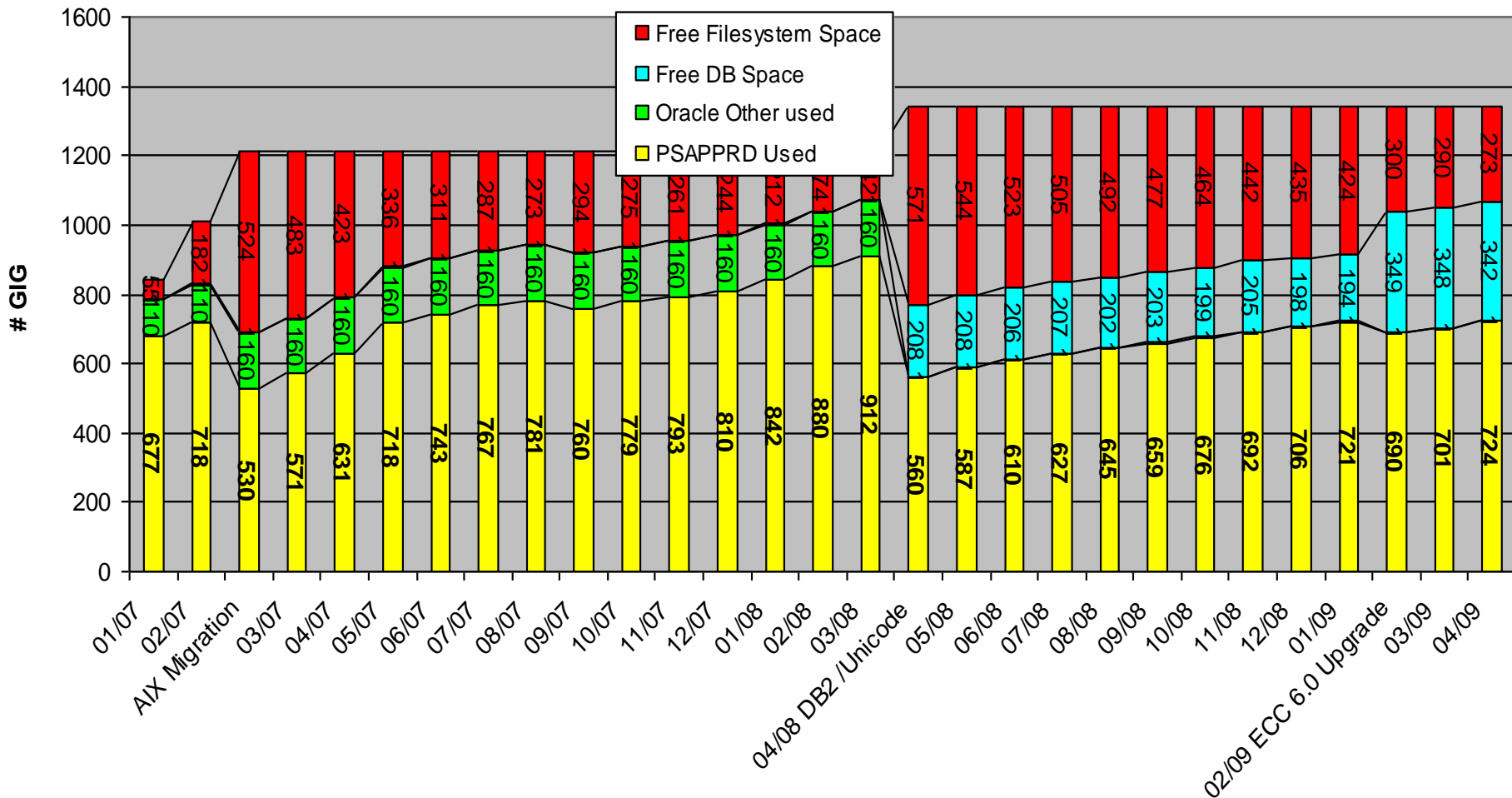

# SAP FORUM 2010

CLAREZA PARA UM NOVO BRASIL

## Agenda



1. About CCBCC
2. Why DB2?
3. Migration
4. Benefits
5. Post migration
6. Satisfaction?

Coca Cola Bottling Company Consolidated

## ■ **Post migration activities**

- Successfully completed two offsite DR tests (R/3, MI)
- Completed SOX auditing
- Migrated all DB2 9.1 → DB2 9.5
- Applied DB2 fixpacks to all systems
- Recovered database after an EMC hardware issue from tape
- Recovered database after a Data Center issue from DB2 backup
- Completed technical upgrade to ECC 6.0 and BI 7.0

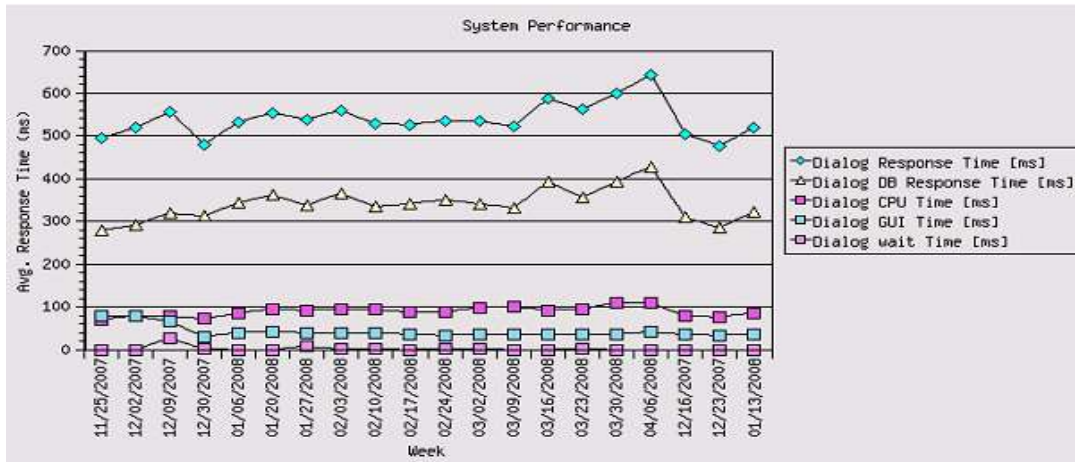

## R/3 performance

Oracle

(11/25/07 – 1/13/08)

[ Non-Unicode ]

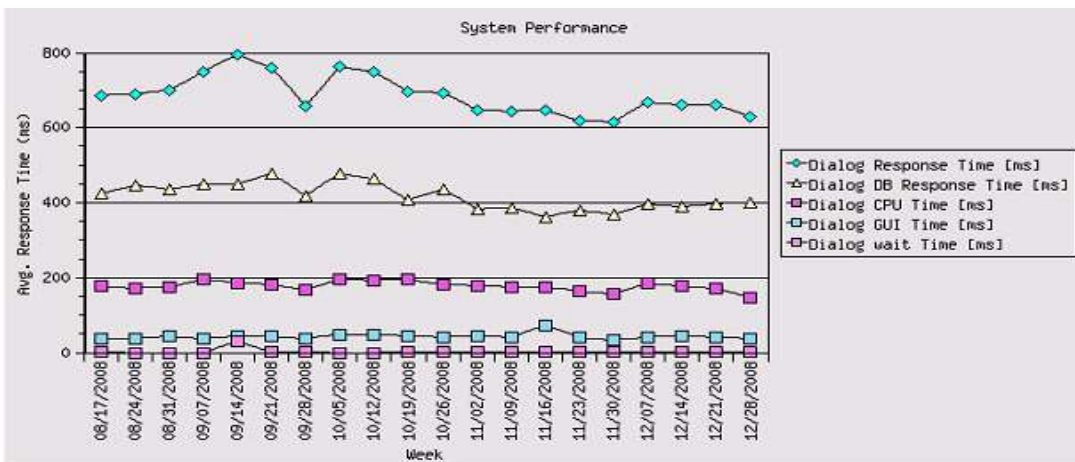

DB2

(8/17/08 – 12/28/08)

[ Unicode ]

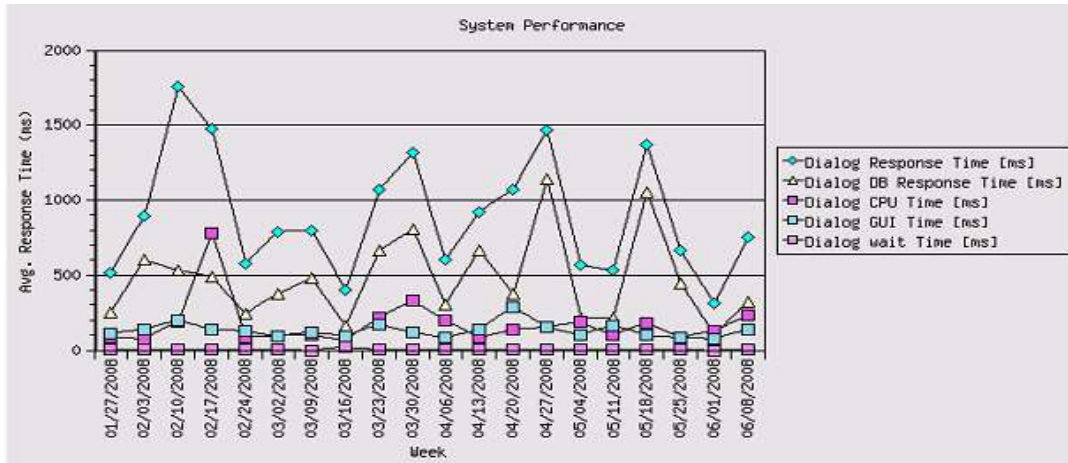

## BW performance

Oracle

(1/27/08 – 6/08/08)

[ Unicode ]

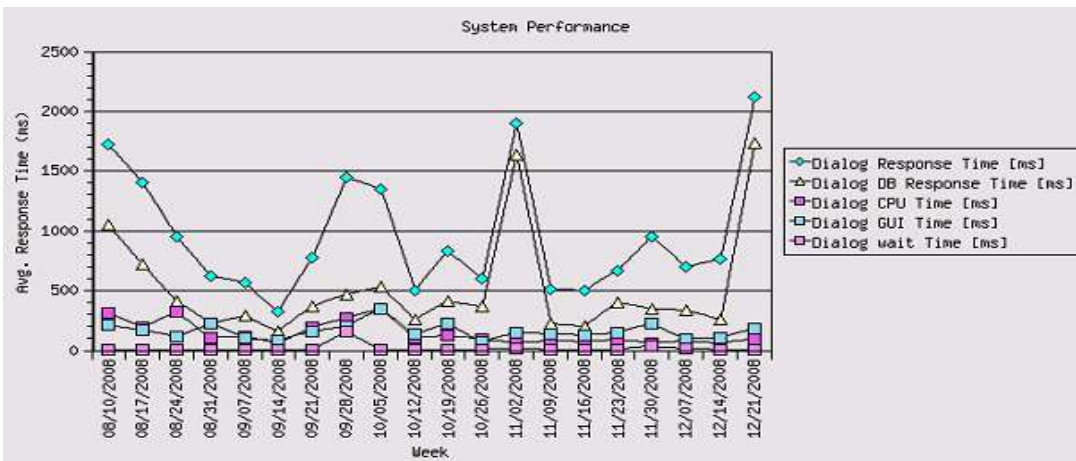

DB2

(8/10/08 – 12/21/08)

[ Unicode ]

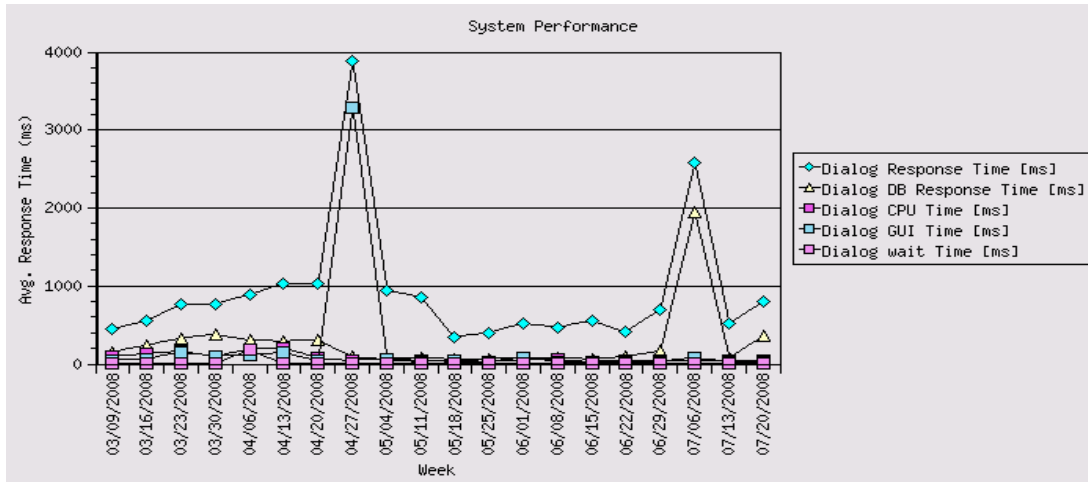

## MI performance

Oracle

(3/9/08 – 7/20/08)

[ Unicode ]

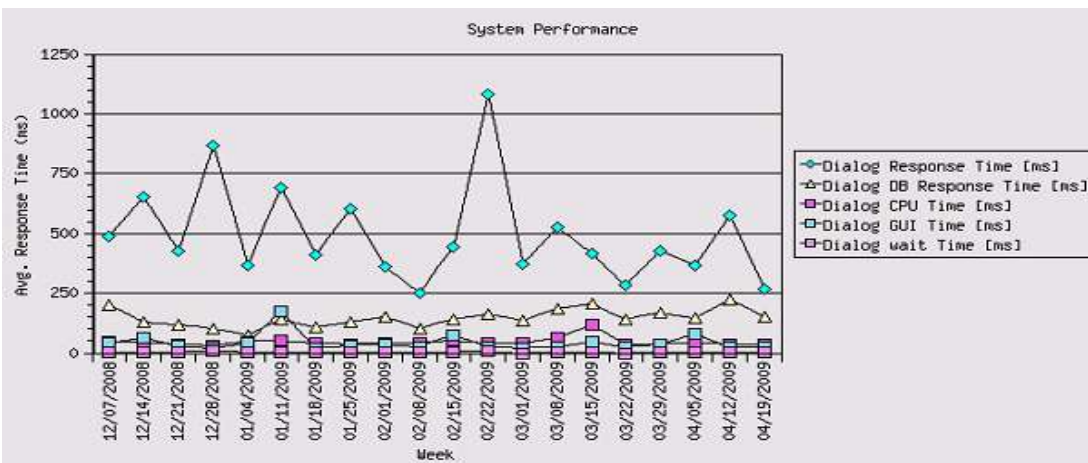

DB2

(12/07/08 – 4/19/09)

[ Unicode ]

# SAP FORUM 2010

CLAREZA PARA UM NOVO BRASIL

## Agenda



1. About CCBCC
2. Why DB2?
3. Migration
4. Benefits
5. Post migration
6. Satisfaction?

Coca Cola Bottling Company Consolidated

# SAP FORUM 2010

CLAREZA PARA UM NOVO BRASIL

SAP





Andrew Juarez, Coca Cola Bottling Company  
Consolidated

Email: [Andrew.Juarez@ccbcc.com](mailto:Andrew.Juarez@ccbcc.com)



# SAP FORUM 2010

CLAREZA PARA UM NOVO BRASIL

**Thank you!**

THE BEST-RUN BUSINESSES RUN SAP™

